

# CoroBore® BR20

Voorkottergereedschappen met twee snijkanten voor flexibel kotteren

## Toepassing

- Voorkotteren
- Tweesnijder kottergereedschap
- Stapsgewijs kotteren
- Trekkend kotteren
- Eénsnijder

ISO toepassingsgebied:



## Voordelen en kenmerken

- Een met lasermarkering aangegeven schaal op de adapter maakt het eenvoudig om de diameter in te stellen
- Een eenvoudiger gereedschapsopbouw voor trekkend kotteren dankzij een unieke slede en afdekplaat
- Ingebouwde functionaliteit voor getrapt kotteren zonder de noodzaak van een extra vulring
- De differentiële vertanding reduceert de neiging tot trillen – de gereedschappen kunnen worden gebruikt bij langere uitsteeklengtes en grotere snededieptes
- Specifieke wisselplaten met vier snijkanten en voor het voorkotteren geoptimaliseerde hardmetaalsoorten
- Spuitmonden met hoge precisie ingebouwd in slede voor het nauwkeurig richten van koelmiddel.
- Snijvloeistof door het gereedschap voor een goede spaanafvoer
- Ook leverbaar als gedempt kottergereedschapassortiment

[www.sandvik.coromant.com/coroborebr20](http://www.sandvik.coromant.com/coroborebr20)

## Klemhouders

Koppelingen:

- Coromant Capto®
- Coromant EH

## Wisselplaten

Standaardwisselplaten met specifieke geometrieën en hardmetaalsoorten voor alle materialen

- CoroBore® 111
- CoroTurn® 107

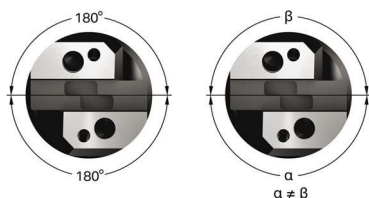

De differentiële vertanding reduceert de neiging tot trillen. De gereedschappen kunnen worden gebruikt bij langere uitsteeklengtes en grotere snededieptes.



Specifieke CoroBore® 111 voorkotterwisselplaten. Met uitstekende spaanbreking en langere standtijd.



●●● SilentTools®

De probleemplosser bij bewerkingen met lange uitsteeklengtes. Het gebruik van Silent Tools™ maakt het mogelijk om de snedediepte te verdubbelen en tegelijkertijd productief te kottteren.

# CoroBore® BR20 voorkottergereedschap met twee snijkanten

Coromant EH - interne koelmiddeltoevoer

KAPR

90°

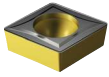

- CCMT, CCGT  
CCGX, CCET
- CCMW

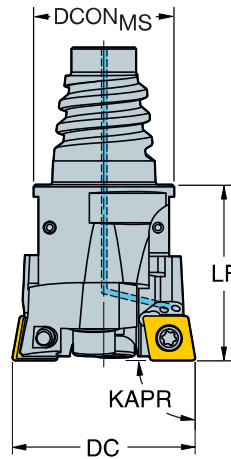

					Afmetingen, mm							
DCN	DCX		CZC <sub>MS</sub>	CNSC	Bestelnummer	DCON <sub>MS</sub>	ADJLX <sub>RDL</sub>	LF			CICT	MIID
23.00	29.00	06	E20	1	BR20-29CC06F-EH20	19.30	3.00	25.00	70	0.070	2	CCMT 06 02 04
28.00	36.00	06	E25	1	BR20-36CC06F-EH25	24.20	4.00	25.00	70	0.110	2	CCMT 06 02 04

Ga voor kotttergereedschappen, toebehoren en onderdelen naar [www.sandvik.coromant.com](http://www.sandvik.coromant.com)  
 Zie voor wisselplaten de Draaigereedschappencatalogus



# CoroBore® BR20 voorkottergereedschap met twee snijkanten

Coromant Capto® - inwendige koelmiddeltoevoer



CCMT, CCGT  
CCGX, CCET  
 CCMW

KAPR  
DSGN

90°  
1

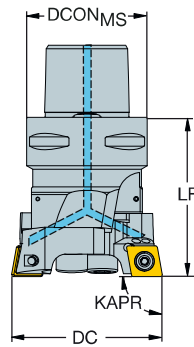

90°  
2

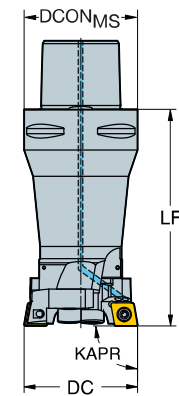

K

Afmetingen, mm

DCN	DCX		CZG <sub>MS</sub>	CNSC	DSGN	Bestelnummer	DCON <sub>MS</sub>	ADJLX <sub>RDL</sub>	ULDR	LF	BD <sub>1</sub>			CICT	MIID
23,00	29,00	06	C3	3	2	BR20-29CC06F-C3	32,00	3,00	2,00	76,00	20,00	70	0,260	2	CCMT 06 02 04
28,00	36,00	06	C3	3	2	BR20-36CC06F-C3	32,00	4,00	2,00	83,00	24,00	70	0,360	2	CCMT 06 02 04
35,00	45,00	09	C3	3	1	BR20-45CC09F-C3	32,00	5,00		48,00		70	0,270	2	CCMT 09 T3 08
35,00	45,00	09	C4	3	2	BR20-45CC09F-C4	40,00	5,00	1,50	83,00	30,00	70	0,560	2	CCMT 09 T3 08
44,00	56,00	09	C4	3	1	BR20-56CC09F-C4	40,00	6,00		56,00		70	0,480	2	CCMT 09 T3 08
44,00	56,00	09	C5	3	2	BR20-56CC09F-C5	50,00	6,00	1,50	98,00	39,00	70	1,030	2	CCMT 09 T3 08
55,00	71,00	12	C5	3	1	BR20-71CC12F-C5	50,00	8,00		66,00		70	0,860	2	CCMT 12 04 08
55,00	71,00	12	C6	3	2	BR20-71CC12F-C6	63,00	8,00	1,50	120,00	50,00	70	1,940	2	CCMT 12 04 08
70,00	90,00	12	C5	3	1	BR20-90CC12F-C5	50,00	10,00		70,00		70	1,230	2	CCMT 12 04 08
70,00	90,00	12	C6	3	1	BR20-90CC12F-C6	63,00	10,00		78,00		70	1,580	2	CCMT 12 04 08
89,00	116,00	12	C6	3	1	BR20-116CC12F-C6	63,00	13,50		90,00		70	2,080	2	CCMT 12 04 08
89,00	116,00	12	C8	3	1	BR20-116CC12F-C8	80,00	13,50		94,00		70	2,990	2	CCMT 12 04 08
115,00	150,00	12	C6	3	1	BR20-150CC12F-C6	63,00	17,50		90,00		70	2,380	2	CCMT 12 04 08
115,00	150,00	12	C8	3	1	BR20-150CC12F-C8	80,00	17,50		100,00		70	3,630	2	CCMT 12 04 08

Ga voor kotttergereedschappen, toebehoren en onderdelen naar [www.sandvik.coromant.com](http://www.sandvik.coromant.com)

Zie voor wisselplaten de Draaigereedschappencatalogus

Voor alle DSGN 2; LU = DC\*ULDR

M

N



L2



M1



N23



N15





K85

# CoroBore® BR20 voorkottergereedschap met twee snijkanten

Coromant EH - interne koelmiddeltoevoer





-  TCMT, TCMX, TCGT, TCGX, TCEX
-  TCMW

KAPR

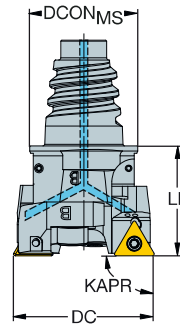
90°



Afmetingen, mm

DCN	DCX		CZC <sub>MS</sub>	CNSC	Bestelnummer	DCON <sub>MS</sub>	ADJLX <sub>FDL</sub>	LF			CICT	MIID
28.00	36.00	09	E25	1	BR20-36TC09F-EH25	24.20	4.00	25.00	70	0.130	2	TCMT 09 02 04

Ga voor kotttergereedschappen, toebehoren en onderdelen naar [www.sandvik.coromant.com](http://www.sandvik.coromant.com)  
 Zie voor wisselplaten de Draaigereedschappencatalogus



L2



M1



N23



N15



K85

# CoroBore® BR20 voorkottergereedschap met twee snijkanten

Coromant Capto® - inwendige koelmiddeltoevoer



- TCMT, TCMX, TCGT, TCGX, TCEX
- TCMW

KAPR  
DSGN

90°  
1

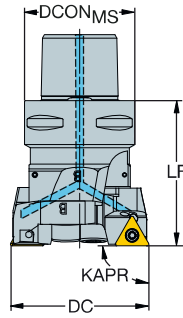

90°  
2

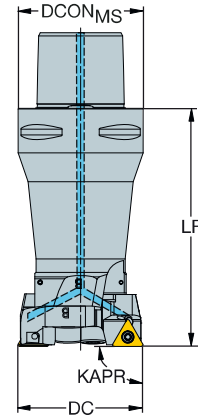

K

							Afmetingen, mm									
DCN	DCX		CZG <sub>MS</sub>	CNSC	DSGN	Bestelnummer	DCON <sub>MS</sub>	ADJLX <sub>RDL</sub>	ULDR	LF	BD <sub>1</sub>			CICT	MIID	
28,00	36,00	09	C3	3	2	BR20-36TC09F-C3	32,00	4,00	2,00	83,00	24,00	70	0,380	2	TCMT 09 02 04	
35,00	45,00	11	C3	3	1	BR20-45TC11F-C3	32,00	5,00		48,00		70	0,270	2	TCMT 11 03 04	
44,00	56,00	11	C4	3	1	BR20-56TC11F-C4	40,00	6,00		56,00		70	0,500	2	TCMT 11 03 04	
55,00	71,00	16	C5	3	1	BR20-71TC16F-C5	50,00	8,00		66,00		70	0,860	2	TCMT 16 T3 08	
70,00	90,00	16	C5	3	1	BR20-90TC16F-C5	50,00	10,00		70,00		70	1,250	2	TCMT 16 T3 08	
70,00	90,00	16	C6	3	1	BR20-90TC16F-C6	63,00	10,00		78,00		70	1,600	2	TCMT 16 T3 08	
89,00	116,00	16	C6	3	1	BR20-116TC16F-C6	63,00	13,50		90,00		70	2,100	2	TCMT 16 T3 08	
115,00	150,00	16	C8	3	1	BR20-150TC16F-C8	80,00	17,50		100,00		70	3,650	2	TCMT 16 T3 08	

Ga voor kotttergereedschappen, toebehoren en onderdelen naar [www.sandvik.coromant.com](http://www.sandvik.coromant.com)

Zie voor wisselplaten de Draaigereedschappencatalogus

Voor alle DSGN 2; LU = DC\*ULDR

L

M

N



# CoroBore® BR20 voorkottergereedschap met twee snijkanten

Coromant Capto® - inwendige koelmiddeltoevoer

KAPR

90°



CNMU

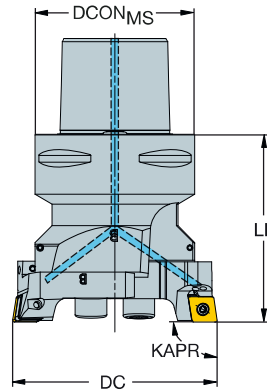

Afmetingen, mm

DCN	DCX		CZC <sub>MS</sub>	CNSC	Bestelnummer	DCON <sub>MS</sub>	ADJLX <sub>RDL</sub>	LF	BAR	KG	CICT	MIID
70.00	90.00	12	C6	3	BR20-90CN12F-C6	63.00	10.00	78.00	70	2.200	2	CNMU 12 04 12
89.00	116.00	12	C8	3	BR20-116CN12F-C8	80.00	13.50	94.00	70	2.900	2	CNMU 12 04 12
115.00	150.00	12	C8	3	BR20-150CN12F-C8	80.00	17.50	100.00	70	3.690	2	CNMU 12 04 12

Ga voor kottergereedschappen, toebehoren en onderdelen naar [www.sandvik.coromant.com](http://www.sandvik.coromant.com)

Zie voor wisselplaten de Draaigereedschappencatalogus



L2



M1



N23



N15



K85



# CoroBore® BR20 voorkottergereedschap met twee snijkanten

Coromant EH - interne koelmiddeltoevoer

KAPR

84°



SPMT

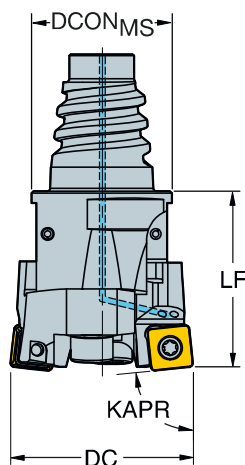

K

Afmetingen, mm

DCN	DCX	CZC <sub>MS</sub>	CNSC	Bestelnummer	DCON <sub>MS</sub>	ADJLX <sub>RDL</sub>	LF	BAR	KG	CICT	MIID
23.00	29.00	06	E20	1 BR20-29SP06Y-EH20	19.30	3.00	25.00	70	0.070	2	SPMT 0606-BM
28.00	36.00	06	E25	1 BR20-36SP06Y-EH25	24.20	4.00	25.00	70	0.110	2	SPMT 0606-BM

Ga voor kotttergereedschappen, toebehoren en onderdelen naar [www.sandvik.coromant.com](http://www.sandvik.coromant.com)

L

M

N



K 12



# CoroBore® BR20 voorkottergereedschap met twee snijkanten

Coromant Capto® - inwendige koelmiddeltoevoer



SPMT



KAPR  
DSGN

84°  
1

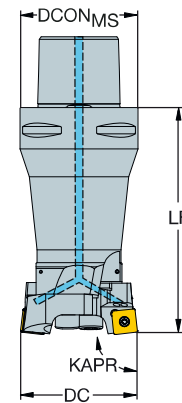
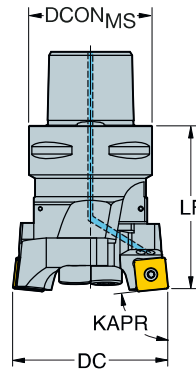
84°  
2



Afmetingen, mm

DCN	DCX		CZC <sub>MS</sub>	CNSC	DSGN	Bestelnummer	DCON <sub>MS</sub>	ADJLX <sub>RDL</sub>	ULDR	LF	BD <sub>1</sub>			CICT	MIID
23.00	29.00	06	C3	3	2	BR20-29SP06Y-C3	32.00	3.00	2.00	76.00	20.00	70	0.260	2	SPMT 0606-BM
28.00	36.00	06	C3	3	2	BR20-36SP06Y-C3	32.00	4.00	2.00	83.00	24.00	70	0.360	2	SPMT 0606-BM
35.00	45.00	08	C3	3	1	BR20-45SP08Y-C3	32.00	5.00		48.00		70	0.270	2	SPMT 0808-BM
35.00	45.00	08	C4	3	2	BR20-45SP08Y-C4	40.00	5.00	1.50	83.00	30.00	70	0.560	2	SPMT 0808-BM
44.00	56.00	08	C4	3	1	BR20-56SP08Y-C4	40.00	6.00		56.00		70	0.480	2	SPMT 0808-BM
44.00	56.00	08	C5	3	2	BR20-56SP08Y-C5	50.00	6.00	1.50	98.00	39.00	70	1.030	2	SPMT 0808-BM
55.00	71.00	12	C5	3	1	BR20-71SP12Y-C5	50.00	8.00		66.00		70	0.860	2	SPMT 1210-BM
55.00	71.00	12	C6	3	2	BR20-71SP12Y-C6	63.00	8.00	1.50	120.00	50.00	70	1.940	2	SPMT 1210-BM
70.00	90.00	12	C5	3	1	BR20-90SP12Y-C5	50.00	10.00		70.00		70	1.230	2	SPMT 1210-BM
70.00	90.00	12	C6	3	1	BR20-90SP12Y-C6	63.00	10.00		78.00		70	1.580	2	SPMT 1210-BM
89.00	116.00	12	C6	3	1	BR20-116SP12Y-C6	63.00	13.50		90.00		70	2.080	2	SPMT 1210-BM
89.00	116.00	12	C8	3	1	BR20-116SP12Y-C8	80.00	13.50		94.00		70	2.990	2	SPMT 1210-BM
115.00	150.00	12	C6	3	1	BR20-150SP12Y-C6	63.00	17.50		90.00		70	2.380	2	SPMT 1210-BM
115.00	150.00	12	C8	3	1	BR20-150SP12Y-C8	80.00	17.50		100.00		70	3.630	2	SPMT 1210-BM

Ga voor kotttergereedschappen, toebehoren en onderdelen naar [www.sandvik.coromant.com](http://www.sandvik.coromant.com)  
 Voor alle DSGN 2; LU = DC\*ULDR



K32



L2



M1



N23



N15



K85





# CoroBore® BR20 gedempt voorkottergereedschap met twee snijkanten

Coromant Capto® - inwendige koelmiddeltoevoer



●●● SilentTools®

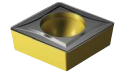

- CCMT, CCGT
- CCGX, CCET
- CCMW

KAPR  
DSGN

90°  
1

90°  
2

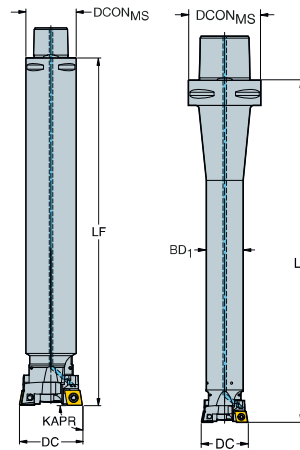

K

							Afmetingen, mm									
DCN	DCX		CZG <sub>MS</sub>	CNSC	DSGN	Bestelnummer	DCON <sub>MS</sub>	ADJLX <sub>RDL</sub>	ULDR	LF	BD <sub>1</sub>			CICT	MIID	
23,00	29,00	06	C4	3	2	BR20D-29CC06F-C4L	40,00	3,00	6,00	199,00	20,00	70	0,740	2	CCMT 06 02 04	
28,00	36,00	06	C3	3	2	BR20D-36CC06F-C3L	32,00	4,00	6,00	216,00	25,00	70	1,030	2	CCMT 06 02 04	
35,00	45,00	09	C3	3	1	BR20D-45CC09F-C3L	32,00	5,00		221,00		70	1,540	2	CCMT 09 T3 08	
35,00	45,00	09	C4	3	2	BR20D-45CC09F-C4L	40,00	5,00	6,00	270,00	32,00	70	1,980	2	CCMT 09 T3 08	
35,00	45,00	09	C6	3	2	BR20D-45CC09F-C6L	63,00	5,00	6,00	297,00	32,00	70	2,620	2	CCMT 09 T3 08	
44,00	56,00	09	C4	3	1	BR20D-56CC09F-C4L	40,00	6,00		220,00		70	2,380	2	CCMT 09 T3 08	
44,00	56,00	09	C5	3	2	BR20D-56CC09F-C5L	50,00	6,00	6,00	336,00	40,00	70	3,720	2	CCMT 09 T3 08	
44,00	56,00	09	C6	3	2	BR20D-56CC09F-C6L	63,00	6,00	6,00	363,00	40,00	70	4,350	2	CCMT 09 T3 08	
55,00	71,00	12	C5	3	1	BR20D-71CC12F-C5M	50,00	8,00		300,00		70	5,080	2	CCMT 12 04 08	
55,00	71,00	12	C6	3	2	BR20D-71CC12F-C6M	63,00	8,00	5,60	400,00	50,00	70	6,940	2	CCMT 12 04 08	
70,00	90,00	12	C6	3	1	BR20D-90CC12F-C6M	63,00	10,00		400,00		70	9,910	2	CCMT 12 04 08	
70,00	90,00	12	C8	3	2	BR20D-90CC12F-C8M	80,00	10,00	5,60	500,00	63,00	70	12,660	2	CCMT 12 04 08	
89,00	116,00	12	C8	3	1	BR20D-116CC12F-C8M	80,00	13,50		500,00		70	18,490	2	CCMT 12 04 08	
89,00	116,00	12	C8	3	1	BR20D-116CC12F-C8S	80,00	13,50		410,00		70	16,140	2	CCMT 12 04 08	
115,00	150,00	12	C8	3	1	BR20D-150CC12F-C8M	80,00	17,50		500,00		70	18,620	2	CCMT 12 04 08	

Ga voor kotttergereedschappen, toebehoren en onderdelen naar [www.sandvik.coromant.com](http://www.sandvik.coromant.com)

Zie voor wisselplaten de Draaigereedschappencatalogus

Voor alle DSGN 2; LU = DC\*ULDR

M

N



L2



M1



N23



N15



K85

# CoroBore® BR20 gedempt voorkottergereedschap met twee snijkanten

Coromant Capto® - inwendige koelmiddeltoevoer

KAPR  
DSGN

90°  
1

90°  
2

●●● SilentTools®



- TCMT, TCMX, TCGT, TCGX, TCEX
- TCMW

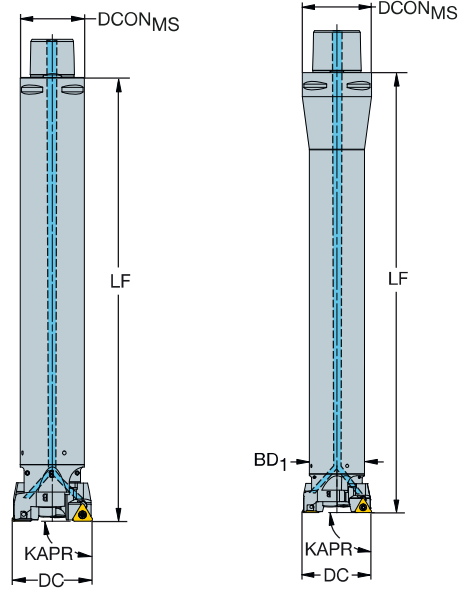

							Afmetingen, mm								
DCN	DCX		CZC <sub>MS</sub>	CNSC	DSGN	Bestelnummer	DCON <sub>MS</sub>	ADJLX <sub>RDL</sub>	ULDR	LF	BD <sub>1</sub>			CICT	MIID
28.00	36.00	09	C3	3	2	BR20D-36TC09F-C3L	32.00	4.00	6.00	216.00	25.00	70	1.718	2	TCMT 09 02 04
35.00	45.00	11	C3	3	1	BR20D-45TC11F-C3L	32.00	5.00		221.00		70	2.330	2	TCMT 11 03 04
35.00	45.00	11	C4	3	2	BR20D-45TC11F-C4L	40.00	5.00	6.00	270.00	32.00	70	1.980	2	TCMT 11 03 04
44.00	56.00	11	C4	3	1	BR20D-56TC11F-C4L	40.00	6.00		220.00		70	2.400	2	TCMT 11 03 04
44.00	56.00	11	C5	3	2	BR20D-56TC11F-C5L	50.00	6.00	6.00	336.00	40.00	70	5.740	2	TCMT 11 03 04
55.00	71.00	16	C5	3	1	BR20D-71TC16F-C5M	50.00	8.00		300.00		70	5.080	2	TCMT 16 T3 08
70.00	90.00	16	C6	3	1	BR20D-90TC16F-C6M	63.00	10.00		400.00		70	9.930	2	TCMT 16 T3 08
89.00	116.00	16	C8	3	1	BR20D-116TC16F-C8M	80.00	13.50		500.00		70	22.085	2	TCMT 16 T3 08
89.00	116.00	16	C8	3	1	BR20D-116TC16F-C8S	80.00	13.50		410.00		70	16.160	2	TCMT 16 T3 08
115.00	150.00	16	C8	3	1	BR20D-150TC16F-C8M	80.00	17.50		500.00		70	23.200	2	TCMT 16 T3 08

Ga voor kotttergereedschappen, toebehoren en onderdelen naar [www.sandvik.coromant.com](http://www.sandvik.coromant.com)  
 Zie voor wisselplaten de Draaigereedschappencatalogus  
 Voor alle DSGN 2; LU = DC\*ULDR



L2



M1



N23



N15



K85



# CoroBore® BR20 gedempt voorkottergereedschap met twee snijkanten

Coromant Capto® - inwendige koelmiddeltoevoer

KAPR  
DSGN

84°  
1



84°  
2

●●●● SilentTools®

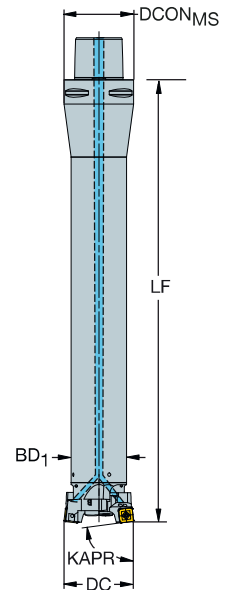
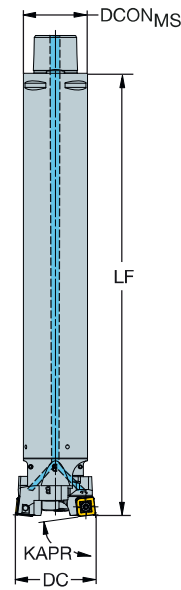

SPMT



										Afmetingen, mm						
DCN	DCX		CZC <sub>MS</sub>	CNSC	DSGN	Bestelnummer	DCON <sub>MS</sub>	ADJLX <sub>RDL</sub>	ULDR	LF	BD <sub>1</sub>			CICT	MIID	
23.00	29.00	06	C4	3	2	BR20D-29SP06Y-C4L	40.00	3.00	6.00	199.00	20.00	70	0.740	2	SPMT 0606-BM	
28.00	36.00	06	C3	3	2	BR20D-36SP06Y-C3L	32.00	4.00	6.00	216.00	25.00	70	1.030	2	SPMT 0606-BM	
35.00	45.00	08	C3	3	1	BR20D-45SP08Y-C3L	32.00	5.00		221.00		70	2.330	2	SPMT 0808-BM	
35.00	45.00	08	C4	3	2	BR20D-45SP08Y-C4L	40.00	5.00	6.00	270.00	32.00	70	4.500	2	SPMT 0808-BM	
35.00	45.00	08	C6	3	2	BR20D-45SP08Y-C6L	63.00	5.00	6.00	297.00	32.00	70	2.630	2	SPMT 0808-BM	
44.00	56.00	08	C4	3	1	BR20D-56SP08Y-C4L	40.00	6.00		220.00		70	5.120	2	SPMT 0808-BM	
44.00	56.00	08	C5	3	2	BR20D-56SP08Y-C5L	50.00	6.00	6.00	336.00	40.00	70	3.720	2	SPMT 0808-BM	
44.00	56.00	08	C6	3	1	BR20D-56SP08Y-C6L	63.00	6.00	6.00	363.00	40.00	70	4.350	2	SPMT 0808-BM	
55.00	71.00	12	C5	3	1	BR20D-71SP12Y-C5M	50.00	8.00		300.00		70	7.672	2	SPMT 1210-BM	
55.00	71.00	12	C6	3	2	BR20D-71SP12Y-C6M	63.00	8.00	5.60	400.00	50.00	70	6.940	2	SPMT 1210-BM	
70.00	90.00	12	C6	3	1	BR20D-90SP12Y-C6M	63.00	10.00		400.00		70	12.000	2	SPMT 1210-BM	
70.00	90.00	12	C8	3	2	BR20D-90SP12Y-C8M	80.00	10.00	5.60	500.00	63.00	70	16.183	2	SPMT 1210-BM	
89.00	116.00	12	C8	3	1	BR20D-116SP12Y-C8M	80.00	13.50		500.00		70	22.125	2	SPMT 1210-BM	
89.00	116.00	12	C8	3	1	BR20D-116SP12Y-C8S	80.00	13.50		410.00		70	16.140	2	SPMT 1210-BM	
115.00	150.00	12	C8	3	1	BR20D-150SP12Y-C8M	80.00	17.50		500.00		70	18.620	2	SPMT 1210-BM	

Ga voor kotttergereedschappen, toebehoren en onderdelen naar [www.sandvik.coromant.com](http://www.sandvik.coromant.com)

Voor alle DSGN 2; LU = DC\*ULDR



L2



M1



N23



N15



K85